



Sanitary Flow Indicator



**PUT A WINDOW
IN YOUR
PROCESSING
SYSTEMS**

SLB- 89TC FLOW INDICATOR

Dimensions

Applications

The Sanitary Flow Indicator BIO series is a compact double window design, suitable for a wide range of applications in high purity tubing systems and may be installed in any position to observe fluid flow. This feature ensures that the sight glasses are free-draining and avoids the possibility of fluid retention. The sight flow indicator is usually employed to detect either the presence or absence of solutions, or to observe fluid for turbulence, colour or clarity. The Sanitary Flow Indicator BIO series are ideal for high purity applications.

Advantages

- Can be cleared in situ - SIP / CIP
- Sterilizable – Autoclavable
- Full bore flow path
- Easy to install – compact design with large viewing area
- Stress, Crack and shatter resistant
- High temperature and pressure resistant
- Unique O-Ring seal design minimizes bacteria traps and eliminates possibility of fluid retention
- Built-in mechanical stop- no over tightening of glass insert
- Meets FDA and 3A specifications
- Full material traceability

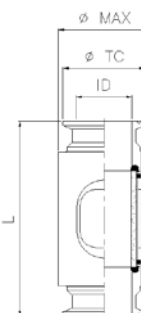

Dimensions table

CODE	TC	ID	L	D max	Borosilicate glass		P max	T max
					OD	Thk		
SLB1/2"-89TC	25,0	9,4	85	25	14,4	2,5	6 bar	121°C
SLB3/4"-89TC	25,0	15,75	85	28	21	2,5	6 bar	121°C
SLB1"-89TC	50,4	22,1	91	39	27,6	2,8	6 bar	121°C
SLB1" 1/2-89TC	50,4	34,8	105	52	41,6	3,3	6 bar	121°C
SLB2"-89TC	64,0	47,5	120	70	56,4	5,2	6 bar	121°C
SLB2" 1/2-89TC	77,5	60,2	151	95	80	9	6 bar	121°C
SLB3"-89TC	91,0	72,9	174	104	90	9	6 bar	121°C
SLB4"-89TC	119,0	97,4	200	127	110	7	6 bar	121°C

The Sanitary Flow Indicator BIO series have two windows at 180° separation

Operating conditions

Design Pressure -1bar to 7 barg (-14,5 psi to 101,5 psi)
 Design temperature -80°C to 150°C (-112°F to 302°F)

Material

Body housing	AISI 316L stainless steel
Ends (no.2)	AISI 316L stainless steel
Insert material	Borosilicate
O-ring (no.2)	EPDM
O-ring (no.2)	EPDM

Surface finish

TK-Connection product contact surface are finish with Ra<0,5 micron or better

Marking

Each Sanitary Flow Indicator BIO is marked with code, material and Heat No. for full lot traceability



SL- 89TC FLOW INDICATOR

Dimensions

Applications

In line FULL VIEW model – SL code for pipe standard according ASTM A269/270
hygienic device may be clamp connected or orbital welded onto a piping system, offer
clear process visibility for fit clamp fittings according BS 4825

Advantages

- Fast and simple installation and maintenance
- Suitable for food processing and sterile applications
- Extremely compact construction with large viewing area
- No product entrapment
- Sterilizable – Autoclavable
- Full bore flow path

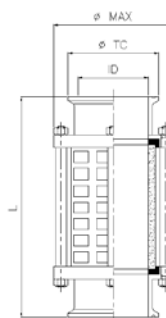

Dimensions table

CODE	TC	ID	L	D max	Borosilicate glass		P max	T max
					OD	Thk		
SL1"-89TC	50,4	22,1	156	64	32	2,8	6 bar	150°C
SL1" 1/2-89TC	50,4	34,8	156	74	50	5	8 bar	150°C
SL2"-89TC	64,0	47,5	156	84	60	5	8 bar	150°C
SL2" 1/2-89TC	77,5	60,2	186	99	75	5	8 bar	150°C
SL3"-89TC	91,0	72,9	218	125	90	5	7 bar	150°C
SL4"-89TC	119,0	97,4	218	145	110	7	6 bar	150°C

L overall length = standard LTC clamped

Special end connections available on request as following:

SL-BS87 BS-OD butt weld/butt weld

SLD-87 DIN 11851 butt weld/butt weld

SLD-89 DIN 11851 female/female

SLD-89A DIN 11851 male+liner/male+liner

SLD-101A flanged PN6/ flanged PN6

Operating conditions

Design Pressure

see above table

Design temperature

-80°C to 150°C (-112°F to 302°F)

Material

Clamp ends (no.2)

AISI 316L stainless steel

Bolts (no.4)

AISI 304 stainless steel

Nuts (no.4)

AISI 304 stainless steel

Insert material

Borosilicate tempered glass

Gaskets (no.2)

Silicone

Optional

AISI 304 splinterproof protection

Other elastomer (EPDM, Viton) available on request

Surface finishing

Product contact surface are finish with Ra<0,5 micron
or better



SP- D54MP FLOW INDICATOR

Dimensions

Applications

In line SEE-THRU model – D54MP series is a compact double window design, suitable for a wide range of applications in high purity tubing systems and may be installed in any position to observe fluid flow. For fit to clamp according BS 4825, pipe standard according ASTM A269 / 270, may be clamp connected or orbital welded onto a piping system, offer clear process visibility

Advantages

- Can be cleaned in situ - SIP/CIP
- Sterilizable – Autoclavable
- Stress, Crack and shatter resistant
- High temperature and pressure resistant
- Meets FDA and 3A specifications
- Full material traceability

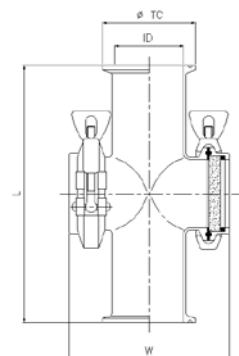

Dimensions table

CODE	TC	ID	L	W	Soda lime glass		P max	T max
					OD	Thk		
SP-D54MP1"	50,4	22,1	140	78	40,5	8	25 bar	150°C
SP-D54MP1" 1/2	50,4	34,8	140	118	40,5	8	25 bar	150°C
SP-D54MP2"	64,0	47,5	178	118	52,5	8	15 bar	150°C
SP-D54MP2" 1/2	77,5	60,2	178	165	66,0	8	9 bar	150°C
SP-D54MP3"	91,0	72,9	155	155	78,5	8	7 bar	150°C
SP-D54MP4"	119,0	97,4	194	195	104,5	10	8 bar	150°C

BS-OD butt weld connections available on request

Operating conditions

Design Pressure -1bar to 7 barg (-14,5 psi to 101,5 psi)
 Design temperature -80°C to 150°C (-112°F to 302°F)

Material

Body housing AISI 316L stainless steel
 Ends (no.2) AISI 316L stainless steel
 Insert material Borosilicate
 O-ring (no.2) EPDM
 O-ring (no.2) EPDM

Surface finish

TK-Connection product contact surface are finish with Ra<0,5 micron or better.

Marking

Each Sanitary Flow Indicator BIO is marked with code, material and Heat No. for full lot traceability.



SLD- 90A FLANGED FLOW INDICATOR

Dimensions

Applications

In line FULL VIEW SLD-90A code for pipe standard according ANSI B 36.10 hygienic device may be clamp connected or orbital welded onto a piping system, offer clear process visibility for fit flanged according UNI 2278-67 PN16

Advantages

- Fast and simple installation and maintenance
- Suitable for food processing and sterile applications
- Extremely compact construction with large viewing area
- No product entrapment
- Sterilizable – Autoclavable
- Full bore flow path

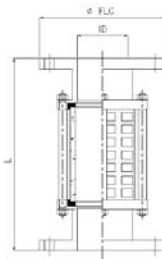

Dimensions table

CODE	DN	ID	L	D flg	Borosilicate glass		P max	T max
					OD	Thk		
SLD 25-90A	25	26,5	162	115	32	2,8	6 bar	150°C
SLD 32-90A	32	33,5	162	140	40	3,2	6 bar	150°C
SLD 40-90A	40	40,0	162	150	50	5	8 bar	150°C
SLD 50-90A	50	50,0	166	165	60	5	8 bar	150°C
SLD 65-90A	65	65,0	196	1805	75	5	8 bar	150°C
SLD 80-90A	80	80,0	248	200	90	5	7 bar	150°C
SLD 100-90A	100	96,0	248	220	110	7	6 bar	150°C
SLD 125-90A	125	126,0	325	250	140	7	5 bar	150°C

L overall length = standard flanged

Special end connections available on request as following:

SL-BS87 BS-OD butt weld/butt weld

SLD-87 DIN 11851 butt weld/butt weld

SLD-89 DIN 11851 female/female

SLD-89A DIN 11851 male+liner/male+liner

Operating conditions

Design Pressure

see above table

Design temperature

-80°C to 150°C (-112°F to 302°F)

Material

Clamp ends (no.2)

AISI 316L stainless steel

Bolts (no.4)

AISI 304 stainless steel

Nuts (no.4)

AISI 304 stainless steel

Insert material

Borosilicate tempered glass

Gaskets (no.2)

Silicone

Optional

AISI 304 splinterproof protection

Other elastomer (EPDM, Viton) available on request

Surface finishing

Product contact surface are finish with Ra<0,5 micron or better



SL2V – SL3V FLOW INDICATOR

Dimensions

Applications

The SL2V-SL3V Flow Indicator is a compact double window design, suitable for a wide range of applications in high purity tubing systems and may be installed in any position to observe fluid flow. This feature ensures that the sight glasses are free-draining and avoids the possibility of fluid retention.

The sight flow indicator is usually employed to detect either the presence or absence of solutions, or to observe fluid for turbulence, colour or clarity. The SL2V –SL3V Flow Indicator are ideal for high purity applications.

Advantages

- Can be cleaned in situ - SIP / CIP
- Sterilizable – Autoclavable
- Full bore flow path
- Compact design with large viewing area
- Stress, Crack and shatter resistant
- High temperature and pressure resistant
- Meets FDA and 3A specifications
- Full material traceability

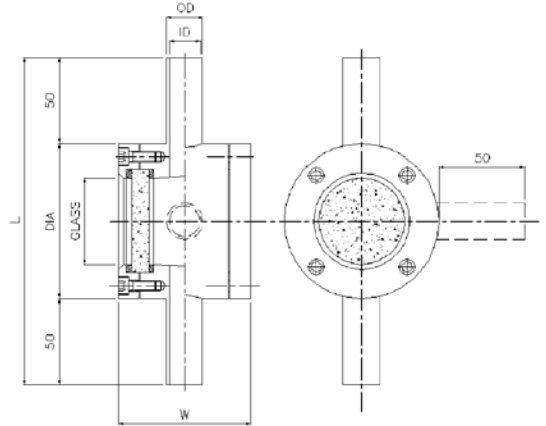

Dimensions table

CODE	OD	ID	L	W	DIA	Glass	Borosilicate glass		P max	T max
							OD	Thk		
SL2-3V - 1/2"	12,7	9,4	190	75	90	50	60	10	7 bar	150°C
SL2-3V - 3/4"	19,05	15,75	190	75	90	50	60	10	7 bar	150°C
SL2-3V - 1"	25,4	22,1	190	75	90	50	60	10	7 bar	150°C
SL2-3V - 1" 1/2	38,1	34,8	240	100	140	100	112	10	7 bar	150°C
SL2-3V - 2"	50,8	47,5	240	100	140	100	112	10	7 bar	150°C
SL2-3V - 2" 1/2	63,5	60,2	240	145	140	100	112	10	7 bar	150°C
SL2-3V - 3"	76,1	72,9	240	145	140	100	112	10	7 bar	150°C
SL2-3V - 4"	101,6	97,4	240	145	140	100	112	10	7 bar	150°C

Operating conditions

Design Pressure -1bar to 7 barg (-14,5 psi to 101,5 psi)
 Design temperature -80°C to 150°C (-112°F to 302°F)

Material

Body housing AISI 316L stainless steel
 Ends (no.2) AISI 316L stainless steel
 Locking ring AISI 316L stainless steel
 Bolts AISI 304 stainless steel
 Insert material Borosilicate tempered glass to DIN 7080
 Gasket (no.2) Virgin PTFE

Surface finish

Product contact surface are finish with Ra<0,5 micron or better

Marking

Each Sanitary Flow Indicator BIO is marked with code, material and Heat No. for full lot traceability

